

WATER HAMMER SHOCK ABSORBER

(Lino Round Level)

Product code 16002616

Product description

When taps, dishwashers and other appliances in the water supply network are closed, a pressure shock is generated in the network. If any part of the network is not well fixed, there will be a clatter noise during a pressure shock. Primarily, the support should always be repaired, but the sound level can also be reduced by installing a pressure damper.

The shock absorber is installed in the water supply near a faucet or washing machine that produces pressure shocks. The damper reduces pressure shock by providing a discharge path for increased pressure. Inside the...

Technical information

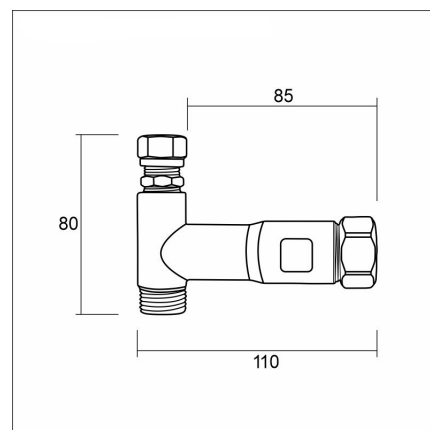

Delivery content



Downloads

- Assembling instructions

Recommended accessories